

(No Model.)

G. A. SANDERS.  
DRILL REST FOR LATHES.

No. 316,185.

Patented Apr. 21, 1885.

Fig 1

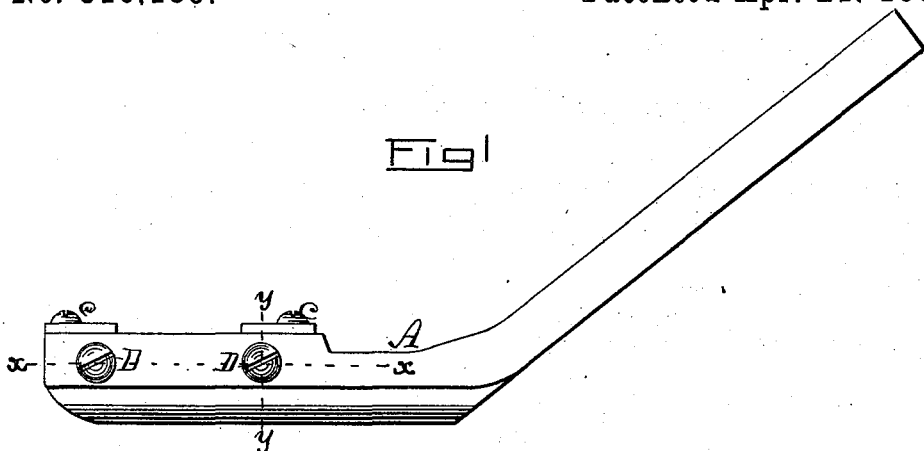

Fig 2

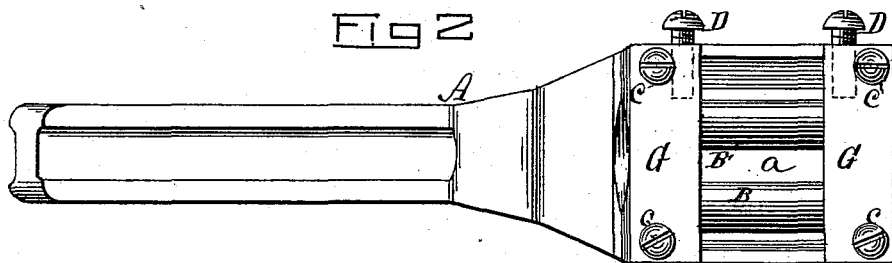

Fig 3

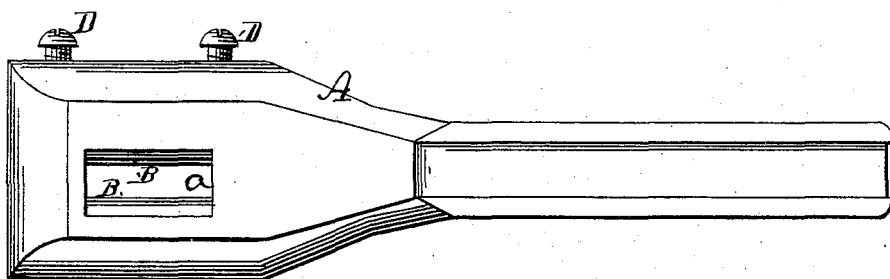

Fig 4

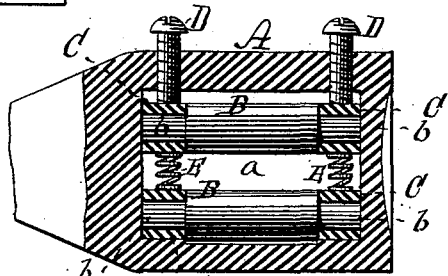
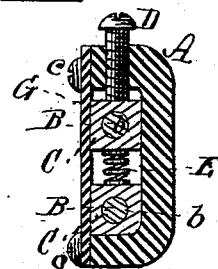

Fig 5



WITNESSES:  
*Arthur S. Brown*  
*J. W. Minter*

INVENTOR:  
*George A. Sanders*  
*By his attorney,*  
*J. S. Brown*

# UNITED STATES PATENT OFFICE.

GEORGE A. SANDERS, OF LAKE VILLAGE, NEW HAMPSHIRE.

## DRILL-REST FOR LATHES.

SPECIFICATION forming part of Letters Patent No. 316,185, dated April 21, 1885.

Application filed November 22, 1884. (No model.)

*To all whom it may concern:*

Be it known that I, GEORGE A. SANDERS, of Lake Village, in the county of Belknap and State of New Hampshire, have invented an Improved Drill-Rest for Lathes; and I do hereby declare that the following is a full and exact description thereof, reference being had to the accompanying drawings, making part of this specification—

Figure 1 being a top view of my improved drill-rest; Fig. 2, a front view of the drill-rest; Fig. 3, a rear view of the same; Fig. 4, a vertical section of the drill-rest in a plane indicated by the line *x x*, Fig. 1; Fig. 5, a vertical section of the same in a plane indicated by the line *y y*, Fig. 1.

Like letters designate corresponding parts in all of the figures.

My invention consists in an improved construction of drill-rests for lathes for adapting them to different thicknesses of drills used and for reducing the friction on the edges of the drill bearing against the rest in pressing it forward to the work, the construction at the same time being strong, firm, durable, and convenient.

The drawings represent a drill-rest, A, of ordinary form, adapted to be attached to a lathe-tool post in the usual manner. The drill-holding slot *a* of the rest is of sufficient width from top to bottom on the rear side to admit the thickest drill to be used. In the front side of the rest, around and in front of the slot, is a cavity or recess wider and longer than the said slot. In this cavity two rolls, B B, are placed. They are strong, preferably of hardened steel, and smooth, as shown, or milled or fluted, as desired. They have strong journals *b b* at their ends, which turn in bearing-blocks C C, that are placed in the ends of the cavity. The bearing-blocks of the lower roll rest on the bottom of the cavity, and need not generally, but may, be adjustable up and down. The bearing-blocks of the upper roll are adjustable up and down in ways in the end of the

cavity by means of set-screws D D, screwing down against the upper sides of the said cavity, and as the screws are raised, spiral or equivalent springs E E, located between the upper and lower bearing-blocks at each end of the cavity, keep the upper bearing-blocks up to the screws. The bearing-blocks are held in the cavity by cap-plates G G, which are secured to the front side of the drill-rest by screws *c c*. These caps also furnish one side of the ways in which the bearing-blocks are held and adjusted. They are readily taken off for removing and replacing rolls or bearing-blocks.

By means of these strong solid rolls, arranged one directly over the other, the drills are held very firmly at the tangent lines of the rolls, one vertically opposite to the other, and the drills are held without any tendency to spring or vibrate, no additional space being required for the drill-rest thus constructed. The bearing is the same for all thicknesses of drills, and no strain comes upon them. The upper roll, being adjustable separately at its two ends, may be brought into exact parallelism with the lower roll or not, as may be required.

I claim as my invention—

1. A drill-rest for lathes, provided with rolls B B, located in a cavity thereof in front of the drill-slot and mounted in bearing-blocks C C, one or both pairs of which are adjustable up and down, substantially as and for the purpose herein specified.

2. A drill-rest for lathes, having a cavity in one side around the drill-slot, and provided with rolls B B, mounted in bearing-blocks C C, sliding in ways in the cavity and adjustable to different distances apart by set-screws G G, substantially as herein set forth.

GEO. A. SANDERS.

Witnesses:

W. H. PEPPER,  
A. T. L. DAVIS.